



**Product Name: Eco Cycle Shelter and Rack**

**Product Code: USP/GS12/6HR**

**Size: 4550 mm Long x 2040 mm Wide x 2100 mm High**

**Description: 12 Cycle Capacity Shelter Complete with Sheffield toast rack back panels, side panels**

**2 gates and central infill section**

**Price: £ 3348.00 plus Vat**

**Total Price including Vat £ 4017.60**

**LEAD TIME EX STOCK 5 TO 6 DAYS**

**Carriage: Free UK Mainland delivery** (other destinations please telephone for a quote)

Product information: The Cycle Shelters are made with a mild steel frame and are Plate Mounted Bolt down. The Eco Cycle Shelter is very easy to assemble and is delivered flat pack. The shelter is lightweight yet robust and being galvanised will give maximum protection from rust for many years. This is a full size shelter and will take up to 12 adult cycles. The assembly is very straight forward. The shelters are available in Galvanised finish only however if you want a painted shelter, simply assemble the frame and paint it to the desired colour (leave it to dry) and then fit the sheeting. To hand paint a shelter will only take about 45 minutes.

The Gates are supplied fully built up ready for bolting to Hinges that are already in position

The Cycle Rack is manufactured with 50mm RHS section and is also fully galvanised to BS EN ISO 1461:1999. Complete with flanges for bolting directly to suitable ground surface. Easy to fit and supplied as a self assembly unit, very simple to build up.

To order this product please telephone 01665577022 or email [sales@urbanfab.com](mailto:sales@urbanfab.com). We will need to know the delivery address including post code and how soon you want delivery. The shelter is manufactured in large sections however assembly is a straight forward two person job.



Shelter above shown with 6 hoop rack

Shield Green Trading Company Ltd, T/A Urbanfab.com and Cycleshelters.com Prospect House, Shield Green Farm, Tritlington, Northumberland, NE61 3DX  
 Telephone: 01665577022  
 Email: [sales@urbanfab.com](mailto:sales@urbanfab.com)

furniture  
designed for the  
urban environment

**urban**  
street products

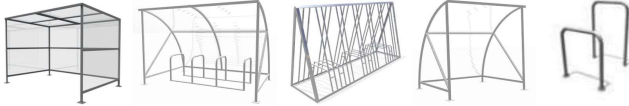

Prospect Building  
Shield Green Farm  
Tritlington  
Northumberland  
NE61 3DX

Tel: 01665 577022  
Email: [stuart@urbanfab.com](mailto:stuart@urbanfab.com)

[www.urbanfab.com](http://www.urbanfab.com)

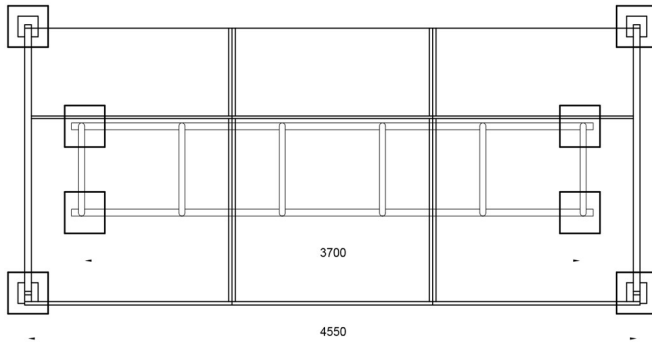

PLAN

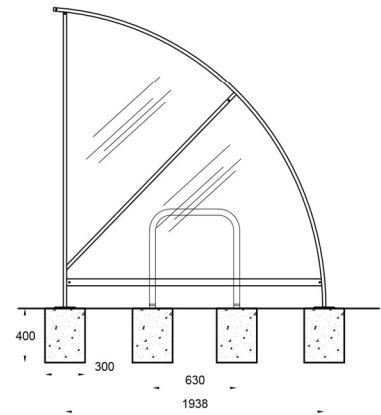

END ELEVATION

C35 CONCRETE SET ON  
FIRM BED OF SAND OR  
CLAY

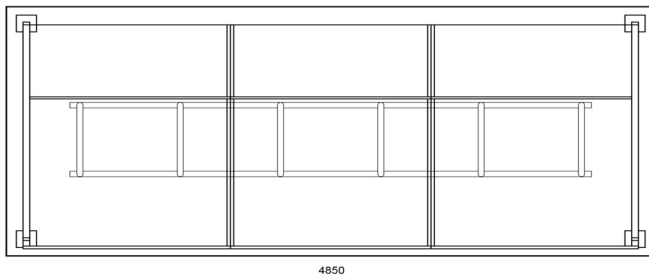

PLAN

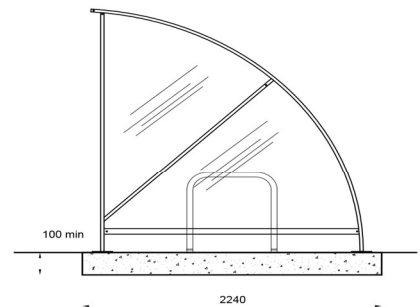

END ELEVATION

C35 CONCRETE SET ON  
FIRM BED OF SAND OR  
CLAY

Shield Green Trading Company Ltd, T/A Urbanfab.com and Cycleshelters.com Prospect House, Shield Green Farm, Tritlington, Northumberland, NE61 3DX  
Telephone: 01665577022  
Email: [sales@urbanfab.com](mailto:sales@urbanfab.com)

furniture  
designed for the  
urban environment

urban  
street products

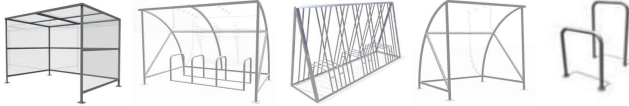

Prospect Building  
Shield Green Farm  
Tritlington  
Northumberland  
NE61 3DX

Tel: 01665 577022  
Email: [stuart@urbanfab.com](mailto:stuart@urbanfab.com)

[www.urbanfab.com](http://www.urbanfab.com)



Shield Green Trading Company Ltd, T/A Urbanfab.com and Cycleshelters.com Prospect House, Shield Green Farm, Tritlington, Northumberland, NE61 3DX  
Telephone: 01665577022  
Email: [sales@urbanfab.com](mailto:sales@urbanfab.com)